

BALDOR® • RELIANCE 

Product Information Packet

VSSWDM3542

.75HP,1740RPM,3PH,60HZ,56C,3518M,TENV,F1

Part Detail							
Revision:	M	Status:	PRD/A	Change #:		Proprietary:	No
Type:	AC	Elec. Spec:	35WGP559	CD Diagram:	CD0005	Mfg Plant:	
Mech. Spec:	35V824	Layout:	35LYV824	Poles:	04	Created Date:	11-24-2010
Base:	N	Eff. Date:	08-12-2019	Leads:	9#18		

Specs			
Catalog Number:	VSSWDM3542	Insulation Class:	F
Enclosure:	TENV	Inverter Code:	Not Inverter
Frame:	56C	KVA Code:	M
Frame Material:	Stainless Steel	Lifting Lugs:	No Lifting Lugs
Output @ Frequency:	.750 HP @ 60 HZ	Locked Bearing Indicator:	Locked Bearing
Synchronous Speed @ Frequency:	1800 RPM @ 60 HZ	Motor Lead Quantity/Wire Size:	9 @ 18 AWG
Voltage @ Frequency:	208.0 V @ 60 HZ	Motor Lead Exit:	Ko Box
	230.0 V @ 60 HZ	Motor Lead Termination:	Flying Leads
	460.0 V @ 60 HZ	Motor Type:	3518M
XP Class and Group:	None	Mounting Arrangement:	F1
XP Division:	Not Applicable	Power Factor:	78
Agency Approvals:	UR	Product Family:	Wash Down All Stainless Steel
	CSA	Pulley End Bearing Type:	Ball
Auxillary Box:	No Auxillary Box	Pulley Face Code:	C-Face
Auxillary Box Lead Termination:	None	Pulley Shaft Indicator:	Standard
Base Indicator:	No Mounting	Rodent Screen:	None
Bearing Grease Type:	Polyrex EM (-20F +300F)	RoHS Status:	ROHS COMPLIANT
Blower:	None	Shaft Extension Location:	Pulley End

Current @ Voltage:	1.100 A @ 460.0 V	Shaft Ground Indicator:	No Shaft Grounding
	2.200 A @ 230.0 V	Shaft Rotation:	Reversible
	2.400 A @ 208.0 V	Shaft Slinger Indicator:	No Slinger
Design Code:	B	Speed Code:	Single Speed
Drip Cover:	No Drip Cover	Motor Standards:	NEMA
Duty Rating:	CONT	Starting Method:	Direct on line
Electrically Isolated Bearing:	Not Electrically Isolated	Thermal Device - Bearing:	None
Feedback Device:	NO FEEDBACK	Thermal Device - Winding:	None
Front Face Code:	Standard	Vibration Sensor Indicator:	No Vibration Sensor
Front Shaft Indicator:	None	Winding Thermal 1:	None
Heater Indicator:	No Heater	Winding Thermal 2:	None

Nameplate NP1951A01										
CAT.NO.	VSSWDM3542									
SPEC.	35V824P559G1									
HP	.75									
VOLTS	208-230/460									
AMP	2.4-2.2/1.1									
RPM	1740									
FRAME	56C				HZ	60			PH	3
SER.F.	1.15		CODE	M	DES	B		CLASS	F	
NEMA-NOM-EFF	82.5			PF	78					
RATING	40C AMB-CONT									
CC									USABLE AT 208V	
DE	6205				ODE	6203				
ENCL	TENV		SN							

Parts List		
Part Number	Description	Quantity
SA212874	SA 35V824P559G1	1.000 EA
RA200103	RA 35V824P559G1	1.000 EA
NS2512A01	INSULATOR, CONDUIT BOX X	1.000 EA
35CB5001A08	CONDUIT BOX KIT, S/P 9-2 (ALL STAINLESS)	1.000 EA
HA5027A02	HA4054 T-DRAIN X2 BAGGED WITH LABEL	1.000 EA
11XW1032G06	10-32 X .38, TAPTITE II, HEX WSHR SLTD U	1.000 EA
HW3001B01	BRASS CUP WASHER, FOR #10 SCREW	1.000 EA
35FE1913A01	FR ENDPLATE ASSY	1.000 EA
HW5100A03	WAVY WASHER (W1543-017)	1.000 EA
35PE1914A02	PU EP ASSY. FOR LOCKED BRG	1.000 EA
HW4606A02	JM CLIPPER/SEAL (LWE-0938-1624-AL23)	1.000 EA
12XN1032S22	10-32 X 1 3/8 SLOT HEX, STAINLESS STEEL	2.000 EA
HA1049A01	DUBO LOK WASHER SIZE 10 (NYLON LOCK SEAL	2.000 EA
HA1049A01	DUBO LOK WASHER SIZE 10 (NYLON LOCK SEAL	4.000 EA
HW2502D13	SS KEY, 3/16 SQ X 1.375	1.000 EA
HA7000A04	KEY RETAINER 0.625 DIA SHAFTS	1.000 EA
MJ5001A02	732 CL SEALANT 3 OZ DIXIE BEARING 289100	0.001 EA
MJ1000A02	GREASE, MOBIL POLYREX EM - 124047	0.050 LB
HA3100S45	THRU BOLT HEX-HEAD 7.95 10-32	4.000 EA
35PA1066	PKG GRP, PRINT PK1008A06	1.000 EA
PK3082	STYROFOAM CRADLE	1.000 EA
MN416A01	TAG-INSTAL-MAINT no wire (1200/bx) 3/19	1.000 EA

AC Induction Motor Performance Data

Record # 36545 - Typical performance - not guaranteed values

Winding: 35WGP559-R005	Type: 3518M	Enclosure: TENV
-------------------------------	--------------------	------------------------

Nameplate Data				460 V, 60 Hz: High Voltage Connection	
Rated Output (HP)	.75			Full Load Torque	2.27 LB-FT
Volts	208-230/460			Start Configuration	direct on line
Full Load Amps	2.4-2.2/1.1			Breakdown Torque	10.4 LB-FT
R.P.M.	1740			Pull-up Torque	6.64 LB-FT
Hz	60	Phase	3	Locked-rotor Torque	7.43 LB-FT
NEMA Design Code	B	KVA Code	M	Starting Current	9.74 A
Service Factor (S.F.)	1.15			No-load Current	0.647 A
NEMA Nom. Eff.	82.5	Power Factor	78	Line-line Res. @ 25°C	22.2 Ω
Rating - Duty	40C AMB-CONT			Temp. Rise @ Rated Load	78°C
S.F. Amps				Temp. Rise @ S.F. Load	91°C
				Locked-rotor Power Factor	64.1
				Rotor inertia	0.106 LB-FT ²

Load Characteristics 460 V, 60 Hz, 0.75 HP

% of Rated Load	25	50	75	100	125	150	S.F.
Power Factor	35	56	70	78	84	87	82
Efficiency	71.6	81.3	83.4	83.1	81.8	80.4	82.5
Speed	1787	1773	1758	1742	1727	1708	1734
Line amperes	0.686	0.783	0.916	1.09	1.27	1.5	1.19

Performance Graph at 460V, 60Hz, 0.75HP Typical performance - Not guaranteed values

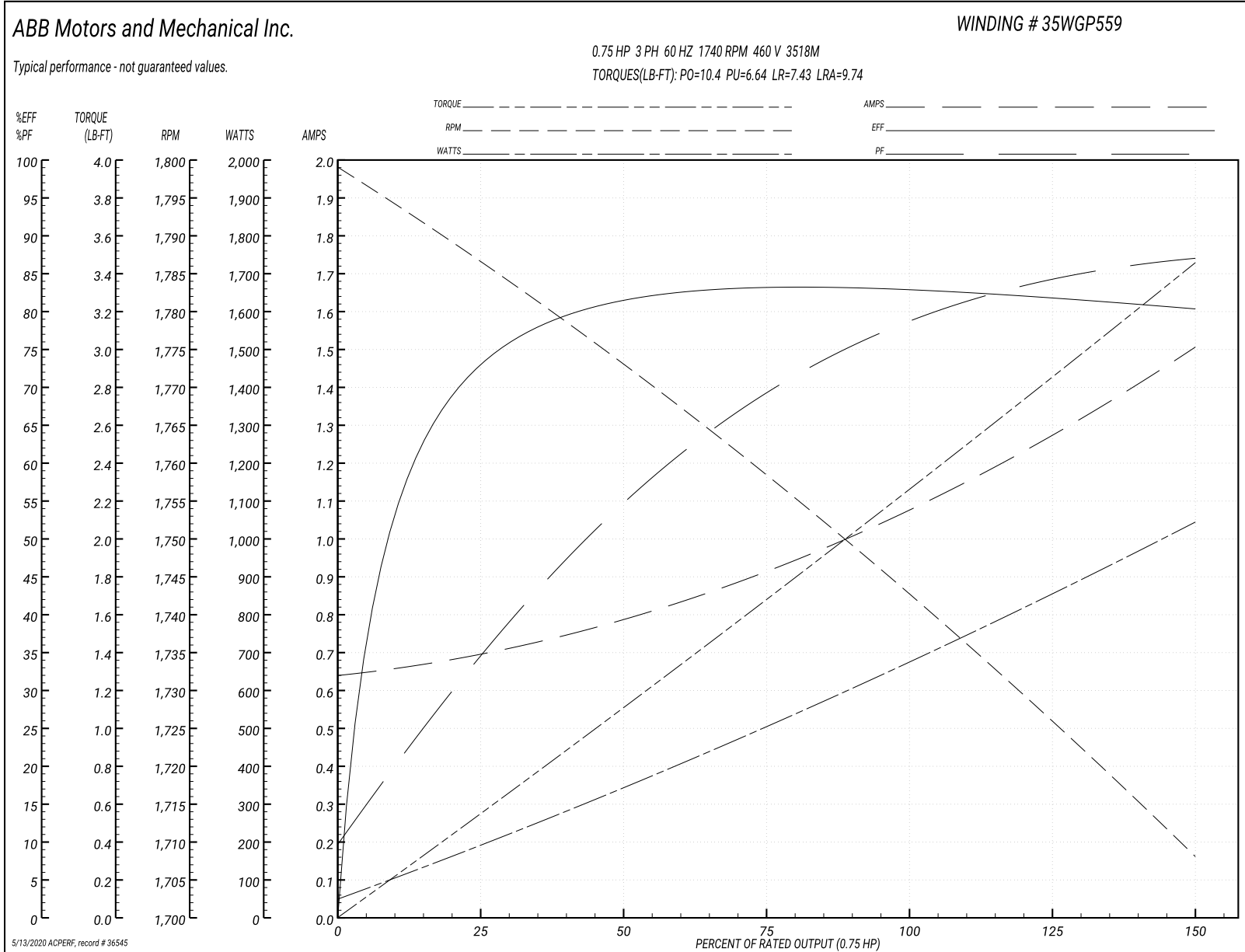

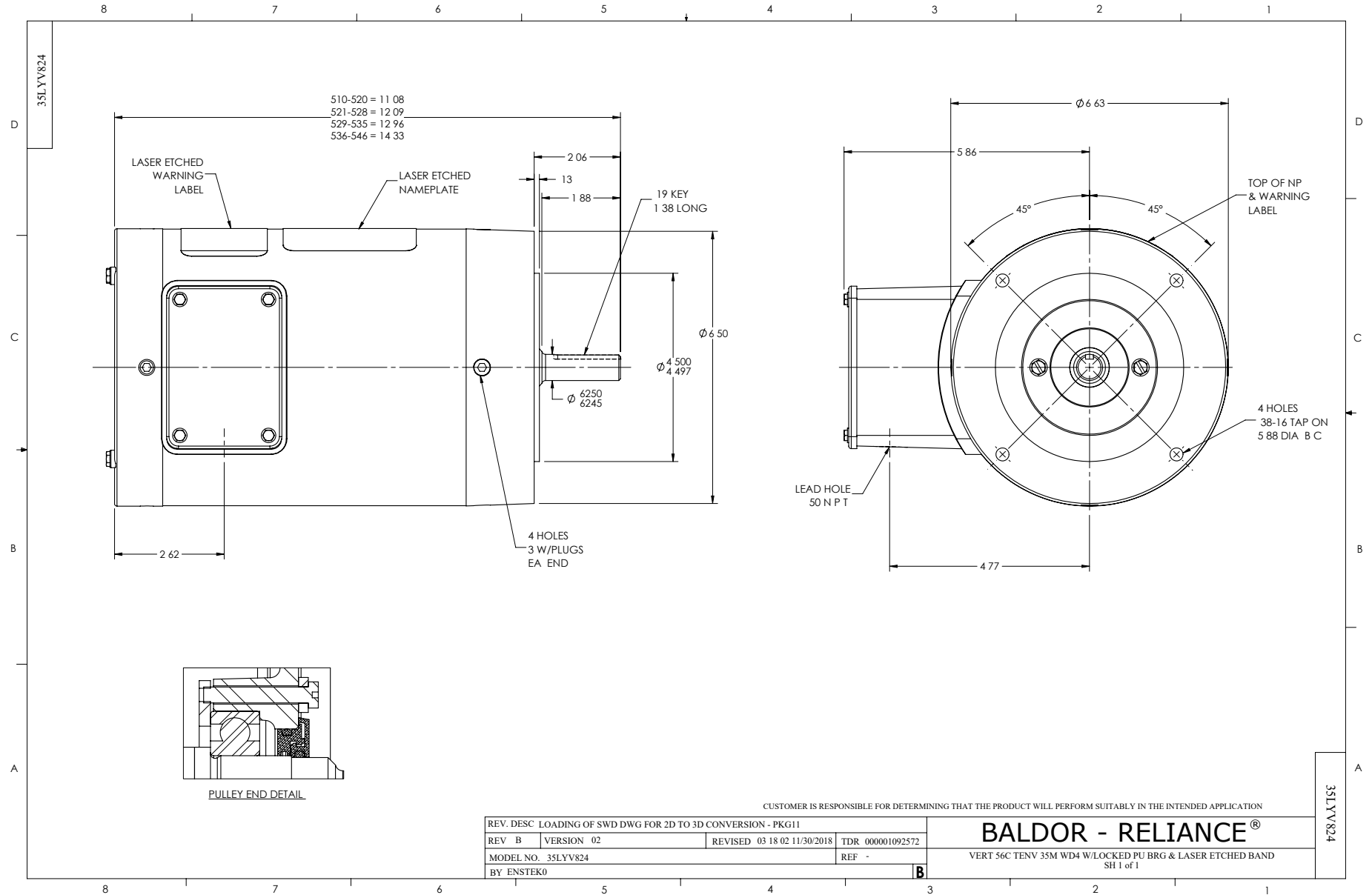

CD0005



LOW VOLTAGE
(2Y)



LINE

HIGH VOLTAGE
(1Y)



LINE

NOTES:

1. INTERCHANGE ANY TWO LINE LEADS TO REVERSE ROTATION.
2. OPTIONAL THERMOSTATS ARE PROVIDED WHEN SPECIFIED.
3. ACTUAL NUMBER OF INTERNAL PARALLEL CIRCUITS MAY BE A MULTIPLE OF THOSE SHOWN ABOVE.
4. LEAD COLORS ARE OPTIONAL. LEADS MUST ALWAYS BE NUMBERED AS SHOWN.

REV. DESC: REVISE TO SHOW OPTIONAL COLORS			
REV. LTR: E	BY: JLP	REVISED: 01/19/99 10:15	TDR: 0171435
90000		FILE: AAA00005140	MDL: -
		MTL: -	

BALDOR ELECTRIC Co.

3PH, DV, 9 LEADS

CD0005